



ZEITLAUF®

antriebstechnik

it's time for tomorrow

Strike



The worm has turned

Bevel gearhead
Standard modular system

EtaCrown®

EtaCrown® – The innovative bevel gearhead with crown gearhead technology.

ZEITLAUF® has revolutionised traditional crown gearheads and broken down technological barriers. We are redefining application possibilities with an innovative and intelligent bevel gearhead.

EtaCrown® is the undisputed No.1* among crown gearheads and provides an outstanding number of additional advantages.

- More power output
- More efficiency
- More productivity
- More torque
- More cost savings

Secure yourself a decisive lead in the market with EtaCrown®. We will be happy to convince you of our vision of making crown gearheads more powerful, smaller and more efficient, and above all, of manufacturing them more economically. It has become a reality.

EtaCrown® – a highlight that moves, driven by innovation.

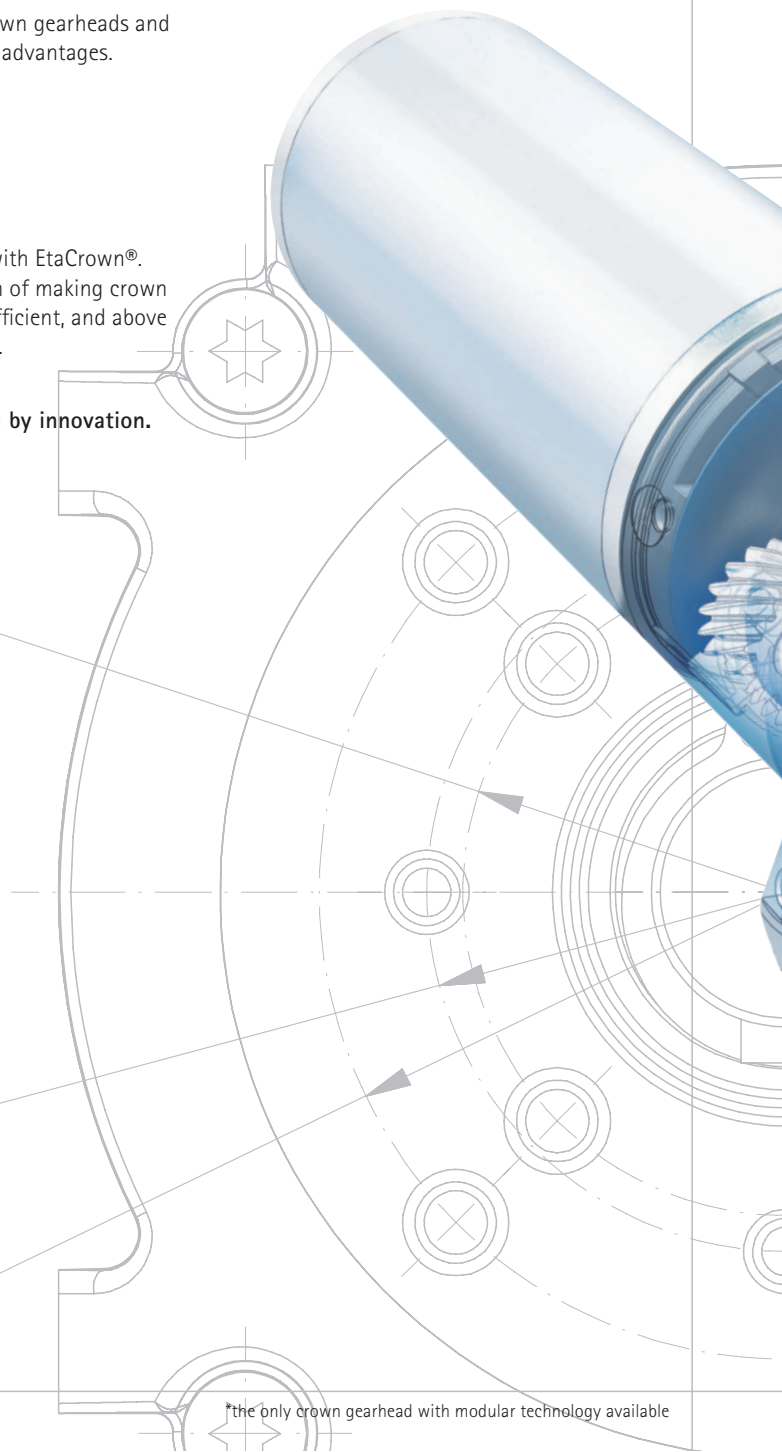

Lucky strike

- Average efficiency is greater than 85 % over the complete range, which means unique energy efficiency
- Extremely smooth running thanks to intelligent gear-tooth technology
- Maximum radial load thanks to double-sided ball bearings on the drive shaft
- Optimum safety in design and operation with no self-locking, smooth surfaces and security against vandalism
- Unbeatable thanks to the compact design and space-saving geometry with symmetrical set-up
- Numerous possible combinations with all standard AC, DC and EC motors
- Gear reduction from 4:1 to 113:1 is available as standard
- Long lifetime thanks to high efficiency, optimized tooth gripping and adapted tooth materials
- Unbeatable economy in terms of both investment and operation
- Modern design
- Jolt-free start-up on account of the rolling tooth gripping

That is the kind of innovation that cannot be more perfect!



EtaCrown® – varied concept

A vision has become reality.

EtaCrown® was created from a clear vision: To significantly increase energy efficiency, flexibility and economy in production and applications, to compress more power and dynamics in a compact design.

The new crown gearhead increases the range of possible applications and brings you enormous innovation potential – both in productivity and efficiency as well as in the flexibility of possible design variants. This means that we have successfully broken through the limits of the traditional crown gearhead in an intensive examination process, and can now offer unusual properties with EtaCrown®.

EtaCrown® – the future begins now!



EtaCrown 75.1 – one-stage crown gearhead

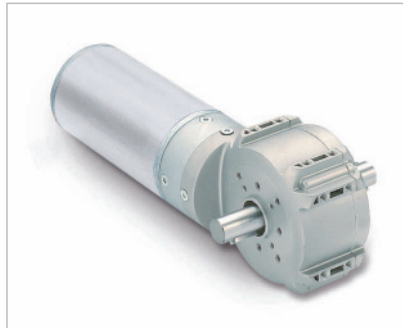

EtaCrown 75.2 – two-stage crown gearhead with planetary pre-stage



EtaCrown 75.2 – two-stage crown gearhead with planetary output stage



EtaCrown® – convincing performances

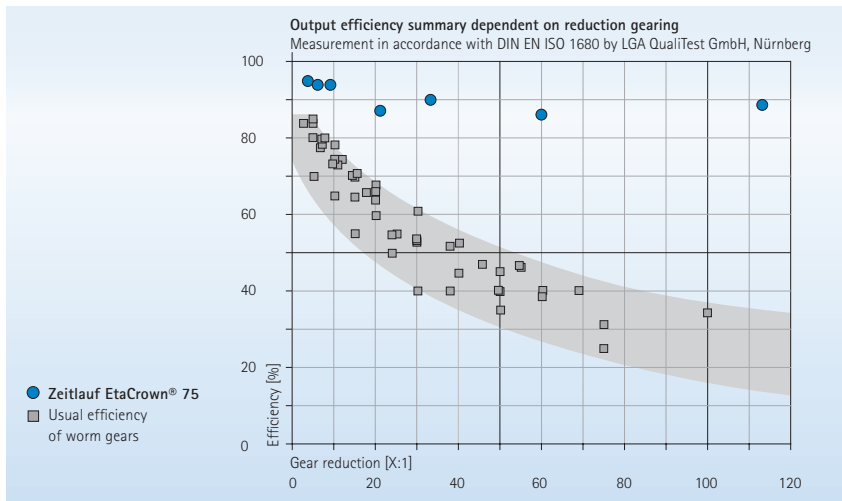

Top efficiency

EtaCrown® has an average efficiency of greater than 90 %, which makes it almost 3.5 times better than a worm gear. The toothed wheels of a crown gearhead roll off one another and do not slide, as is the case with a worm gear. The loss of energy from rolling friction is significantly lower than with sliding friction, which is why with the crown gearhead a considerably greater share of the power supplied is available as output power. This means up to 70 % less loss of power – EtaCrown® is pushing the power limits upwards significantly.

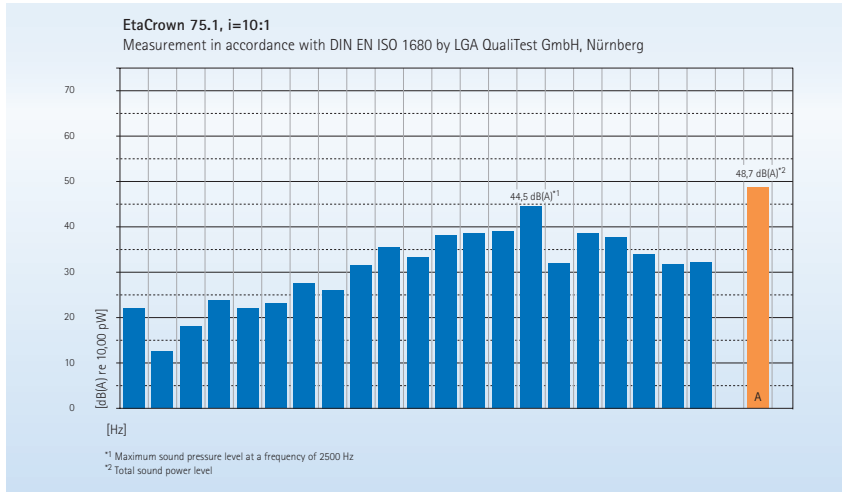

Extremely smooth running

The extremely smooth running typical for ZEITLAUF® gears is also applicable for EtaCrown®, of course. The excellent noise reduction is based on an intelligent gear-tooth technology and the use of plastic materials with optimised sliding properties for planetary wheels and hollow wheel in the preliminary stage as well as the optimum bearing design of the crown stage.

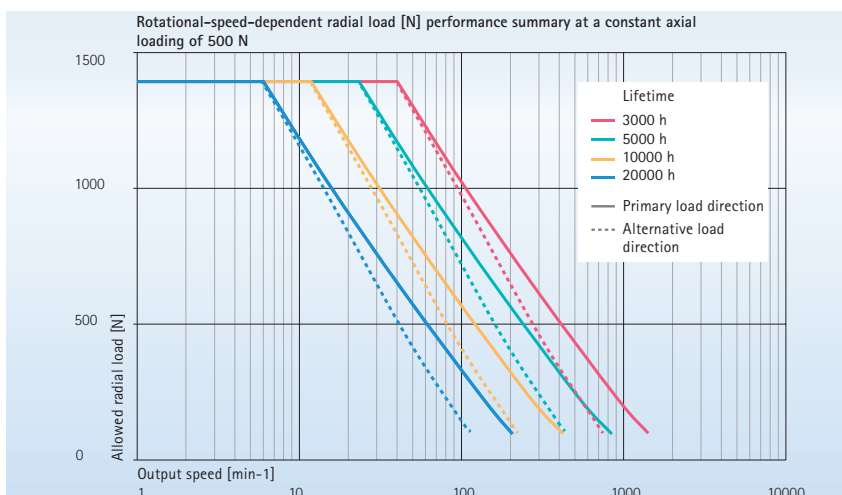

Maximum radial loads

The double-sided support of the drive shaft using high-power ball bearings makes maximum radial loads possible independently of drive speed and service lifetime, and allows a gear lifetime of 20,000 hours.

Energy efficiency

The high capacity and enormous efficiency allow the use of significantly smaller motors with considerably lower energy requirements. The power consumption is reduced by up to 70 %, increasing the tool life of battery-operated solutions up to three times that of worm gears. Thanks to the significant reduction in waste heat in the gear units and motors, additional energy can be saved in the infrastructure of the gear environment, too.

Extremely high safety level

The tooth-gear geometry of the EtaCrown® crown gearhead has an enormous impact on the safety aspects in concept and use. The gearhead has no self-locking and thus enables the drive to be turned back without any damage. Additional coupling mechanisms that are necessary with worm gears are no longer required. The extremely low frictional resistance allows reliable calculations to be made during the design phase.

Unbeatably flexible in use

The increased capacity in terms of output power, a compact geometry and smaller motors make significantly smaller installation dimensions possible for EtaCrown® (while at the same time retaining the output power level). The symmetrical set-up further supports the reduced space requirements.

In addition, the design of the gear housing makes integration in an overall system much easier. There is no motor overhang with EtaCrown®. This avoids recesses or additional spacer flanges to bridge gaps.

The symmetry in the design does away with the necessity for left or right-stop versions as are necessary with worm gears.

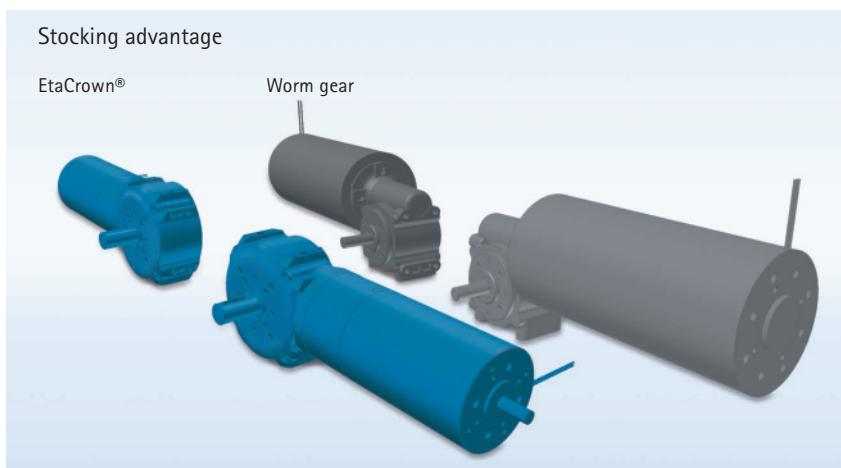
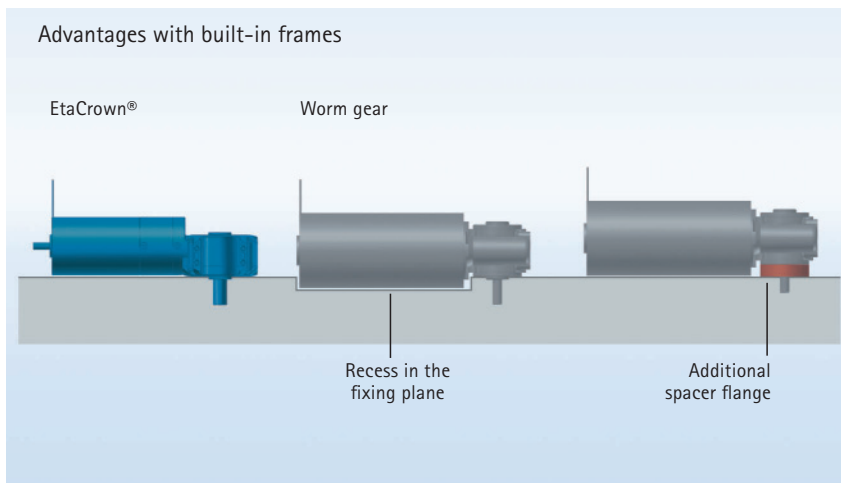
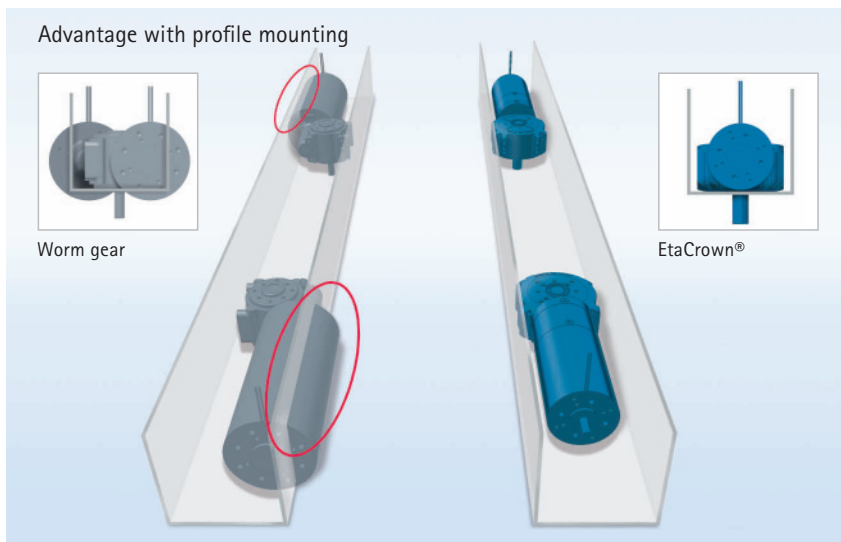

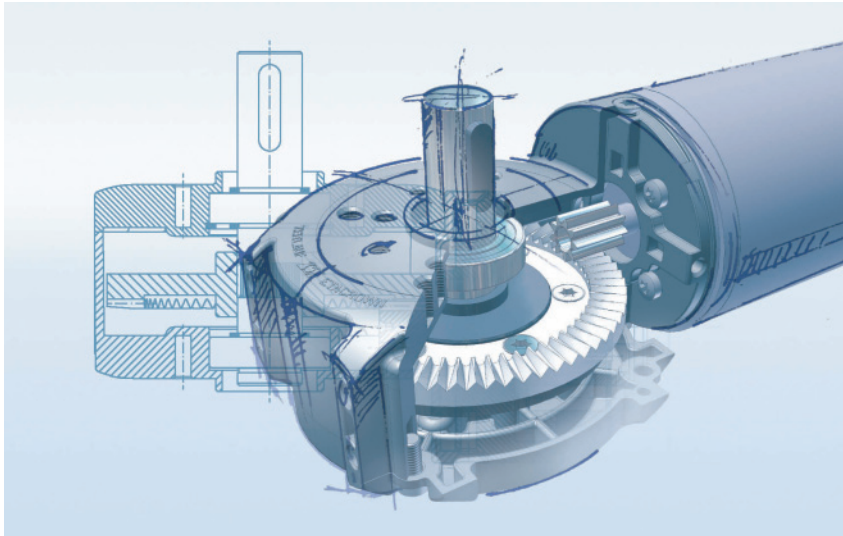

Functional design

The design claim of EtaCrown® in form and function is an expression of its innovative ambition. Its smooth surface guarantees the gear unit high operational safety. In addition, the design and structure ensure pronounced resistance to vandalism.

Optional shaft geometry

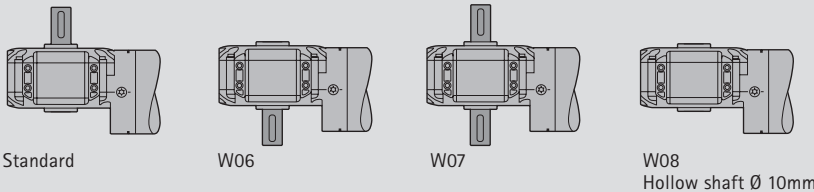

Motor screw-on positions

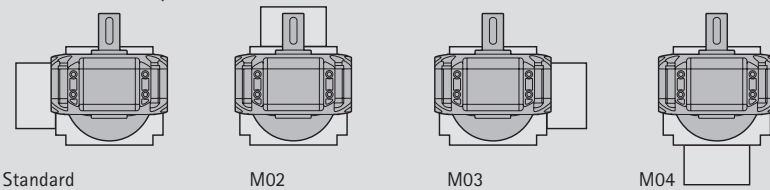

Multitude of applications

EtaCrown® is convincing thanks to flexible application possibilities with different optional shaft outputs and geometries available – to perfectly match application requirements.

Screw-on positions integrated as standard in the housing enables a wide range of screw-on possibilities to be considered for the application right from the very beginning. In addition, the straightforward integration of brake and sensor is possible. Thanks to the combination possibility with all standard AC, DC and EC motors, there are practically no limits to the range of potential applications.

Intelligent, electronically controlled motors combined with the rolling tooth gripping ensure jolt-free start-up.

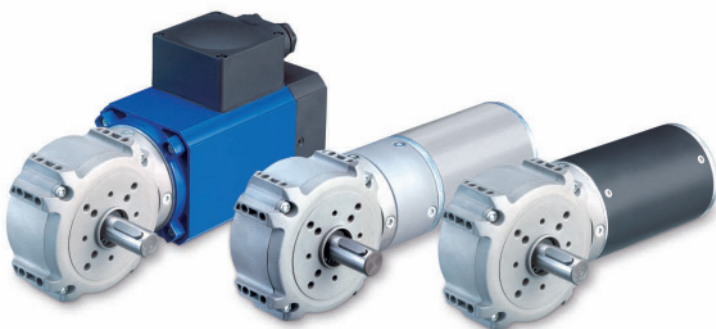

● Support washer

● Deep groove ball bearing

● Crown gearhead housing

● Deep groove ball bearing

● Crown gearhead

Drive shaft ●

● Gear cover

● Feather key

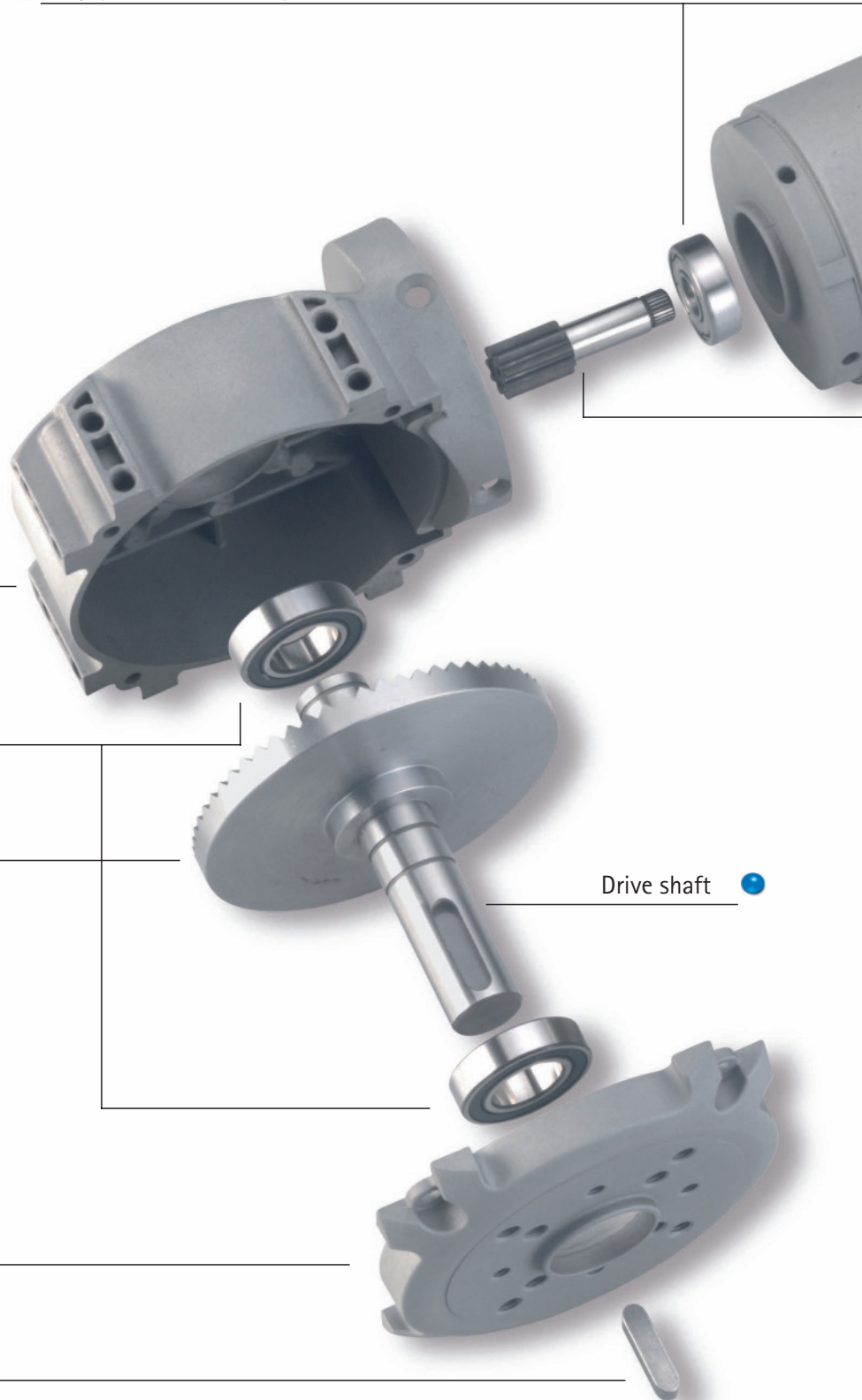

EtaCrown® – infinitely superior

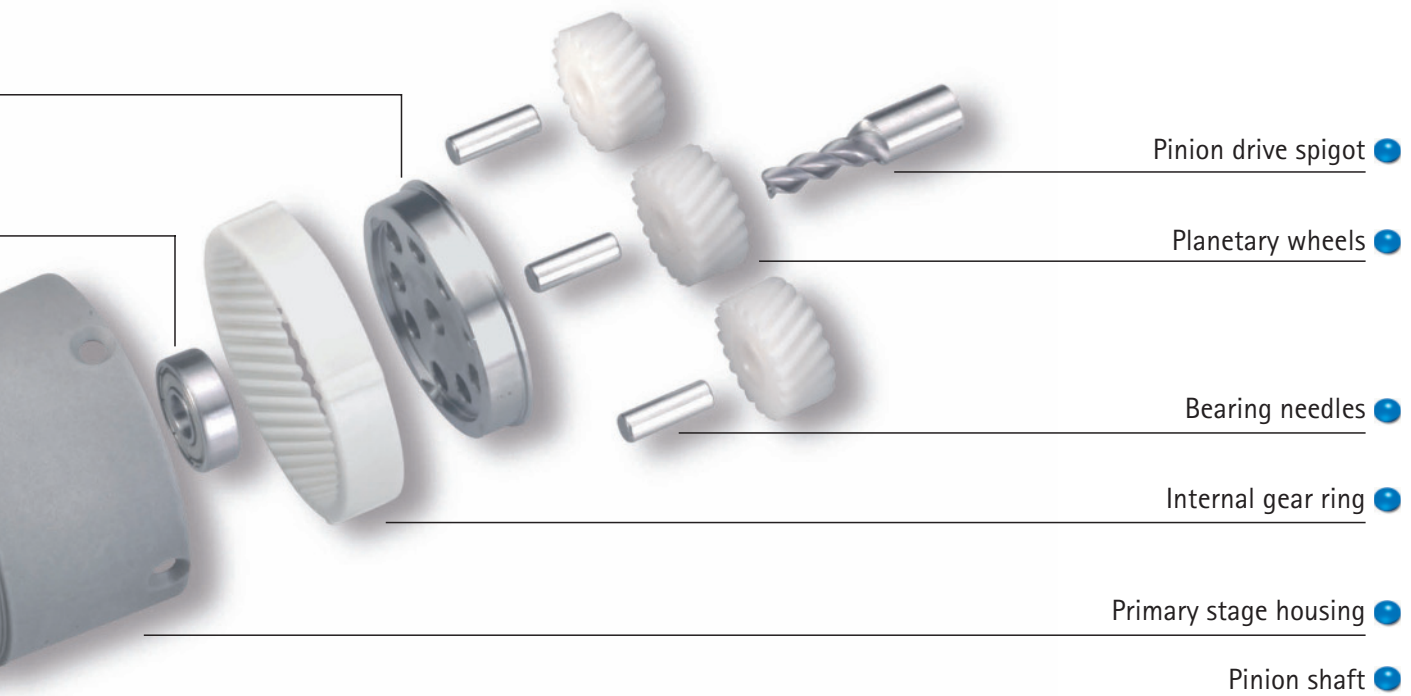

Strike – Intelligence down to the tiniest detail

EtaCrown® stands out thanks to its mature and tried-and-tested technology. Experienced engineering performances at the highest technical and scientific level are behind this. The standard modular system design leads to an enormous increase in design and application possibilities.

Each of the individual components is impressive on account of its excellent material and manufacturing quality. This high quality ensures low-wear operation and an extremely long lifetime.

Thanks to the high efficiency, optimised tooth gripping, the use of steel or POM for the teeth as well as the technological

advantage provided by the rolling movement, a standard service life of 5,000 hours can be guaranteed without question.

Powerful gear reduction performance

Gear reductions of 4:1 up to 113:1 are available as standard. 2-stage gear reductions of up to 170:1 are possible for customer-specific solutions. (3-stage reductions on request)

EtaCrown® – Pure drive power.

Efficiency with unbeatable economy

Alongside the technical intelligence and the excellent features which allow EtaCrown® to break through the upper limits of drive technology, the drive concept is also convincing thanks to its economical efficiency which means unbeatable cost advantages for you in terms of both investment and operation.

Smaller motors and less complex environmental conditions result in significantly lower investments. Lower energy requirements results in further considerable cost reductions. A long lifetime ensures long investment cycles.

The future begins now!

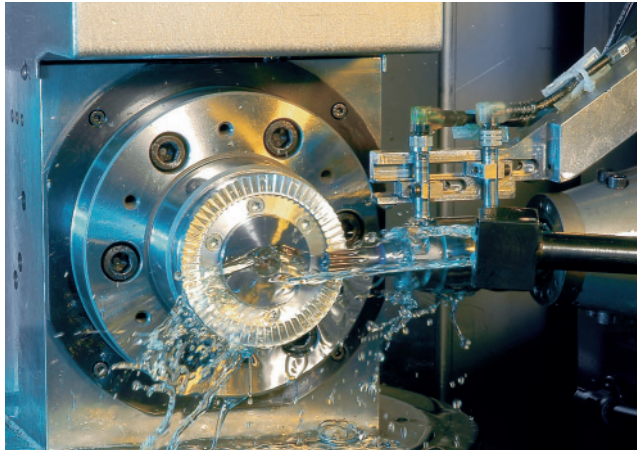

High-quality drive solutions demand perfection

Each of our development concepts is characterised by competent engineering solutions which move the market, where we can be seen to be setting the industry benchmarks. These facts have established us as a recognised technological leader.

Making our customers more successful is our special driving force. Just as is the philosophy of returning top performances in every project and relying on top-level quality. For us, there is no greater challenge than that of enabling our customers' demands to become reality with unique performance ability.

ZEITLAUF® – assuring you the decisive lead in your markets.

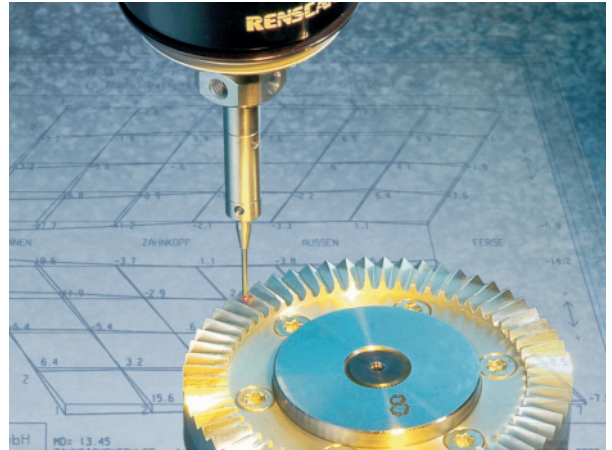

The focus is on your requirements.

We offer you a comprehensive performance package, ranging from individual products from our standard modular system through individually modified gear motors to special developments as complete solutions.

Intensive examination of the problem coupled with first-rate engineering and maximum production quality puts us in the lead in all technological aspects.

In-house software developments for the calculation and simulation of tooth-gear designs, basic research on the manufacturing of gear teeth, production of own rolling slotting machines as well as research projects with renowned colleges of higher education and technology companies stand for our high level of competence.

Consistent quality management in all internal processes and the complete implementation of endurance tests bring you enormous added value and corresponding advantages in your value creation chain. And makes us into your competent partner for successful drive solutions.

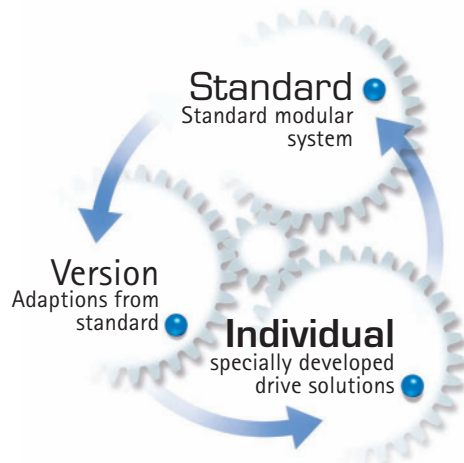

Solutions for your demands

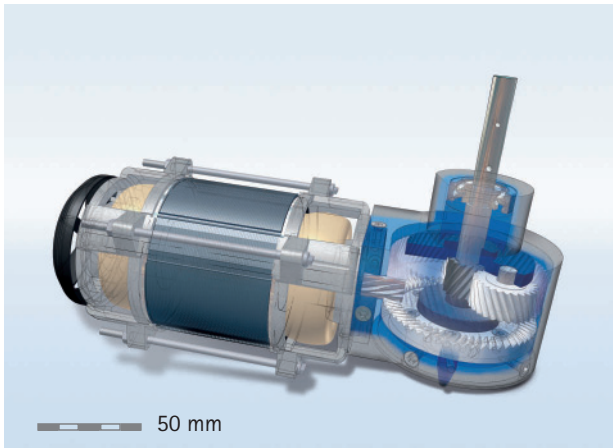

Proof of performance for our engineering expertise.

The quality and value of our development work is clearly demonstrated again and again whenever we face the challenge of individual special requirements. This is where our capacity and variety come in especially useful. Above all, the intelligent adaptation or integration of in-house developed system components into a new, complete functional unit is what makes us stand out from the rest. We would like to underscore the proof of this expertise with a few such examples.

Main drive with shaft output on two sides

Plastic crown gear stage with a downstream planetary gear, both with bevelled teeth. High efficiency minimises waste heat, thus reducing the need for ventilation in the application. Motor diameter 80 mm.

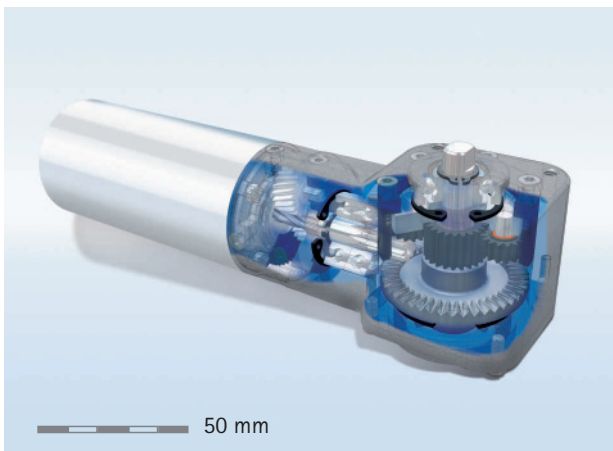

Swivel drive for high torque

Steel crown gear stage with upstream planetary gear with bevelled teeth made of plastic and downstream planetary gear with straight teeth made of hardened steel. Designed for extremely smooth running and high torque transfer, despite the small design space. Motor diameter 42 mm.

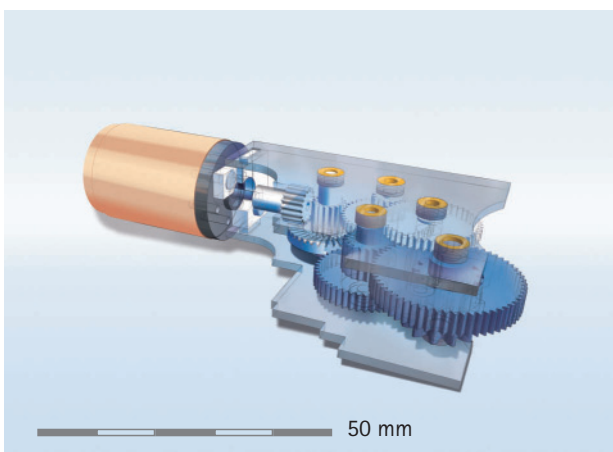

Auxiliary drive in miniature format

Plastic crown gear with 4 downstream spur gear stages made of plastic or steel. Open housing with blank finish. Product size optimised for use in cramped installation situations. Motor diameter just 17 mm.

EtaCrown[®] – ingeniously perfect

EtaCrown[®] is the undisputed No. 1 among crown gearheads*

Put your money on innovation and a technical lead. Make the most of the unique advantages that EtaCrown[®] has to offer you by breaching the limits. Re-define application possibilities with us – today. Because an intelligent vision has already become reality.

We increase your flexibility

Not only the advantages of our drive solution EtaCrown[®] will put you that decisive step ahead. Our philosophy and our concept provide you with the right answers to fast-moving markets. These will make you unbeatably flexible in terms of time, too. We will put you in a position to act quickly so that you can implement your ideas impressively within a short time.



EtaCrown[®] is configured from our standard modular system on demand, and is ready for dispatch for you within 48 hours.

EtaCrown[®] – the worm has turned!

*the only crown gearhead with modular technology available





ZEITLAUF®

antriebstechnik

EtaCrown® 52 with preliminary stage

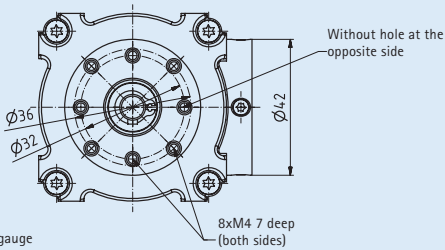
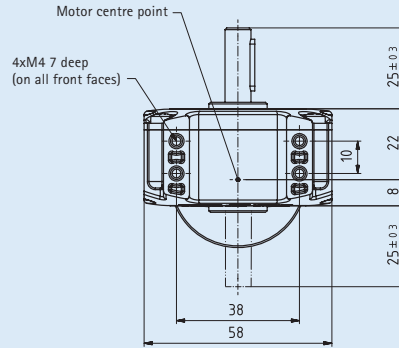
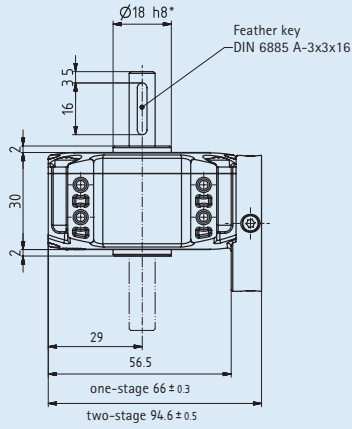

* true to gauge

EtaCrown® 52 with output shaft

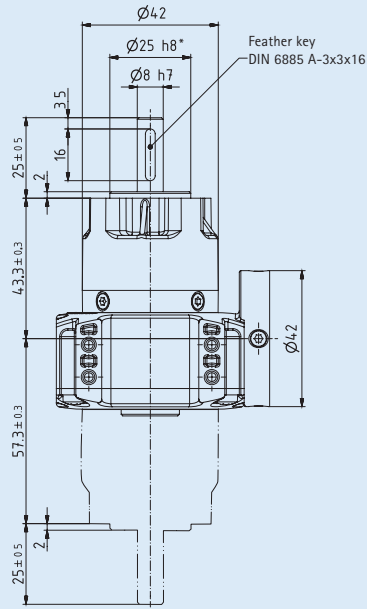

Alternative shaft geometric:

D-shaft

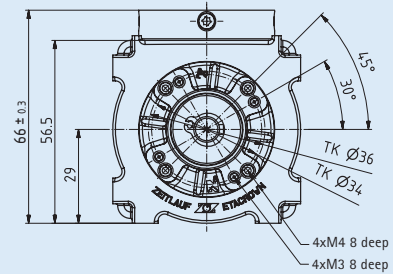
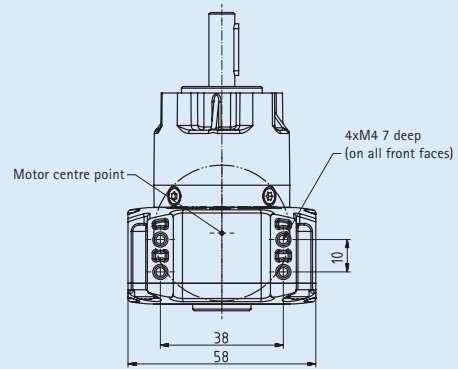
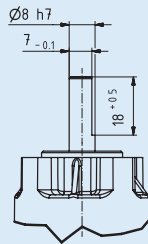

* true to gauge

EtaCrown[®] 75 with preliminary stage

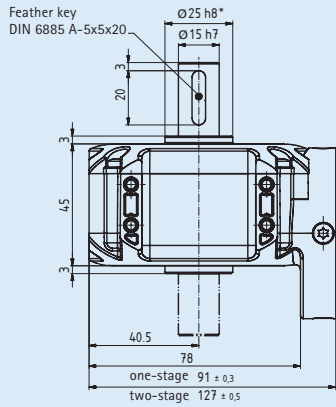

Alternative shaft geometry:
Hollow shaft

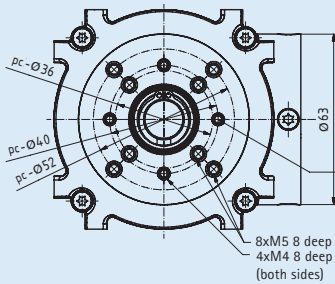
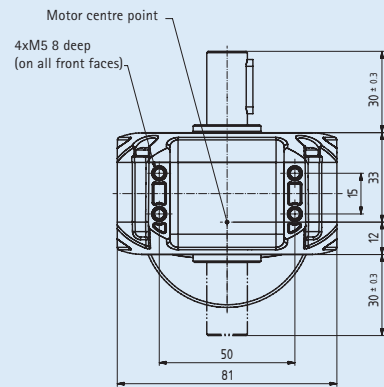
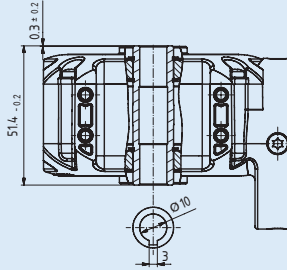

* true to gauge

EtaCrown[®] 75 with output stage

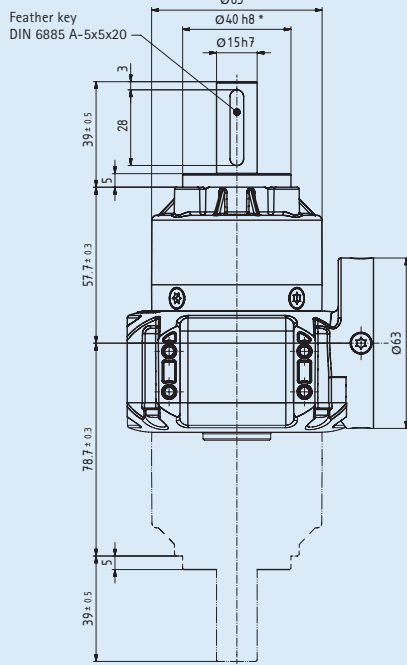

Alternative shaft geometry:
D-shaft

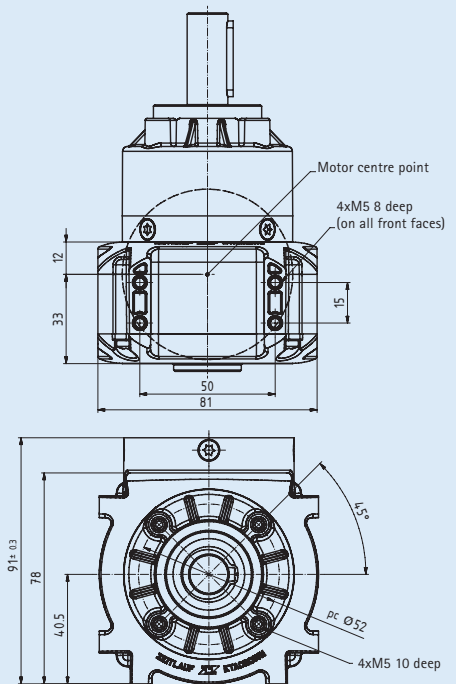
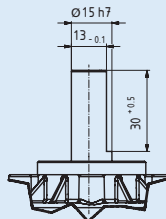

* true to gauge